

Montageanleitung • Assembly Instructions
Instruções de montagem • Monteringsanvisningar

HUMBER

Rattan-Stil Möbel Garnitur • Rattan-Style Furniture Set
Jogo de Mobília Estilo Rotin • Möbeluppsättning I rotting stil

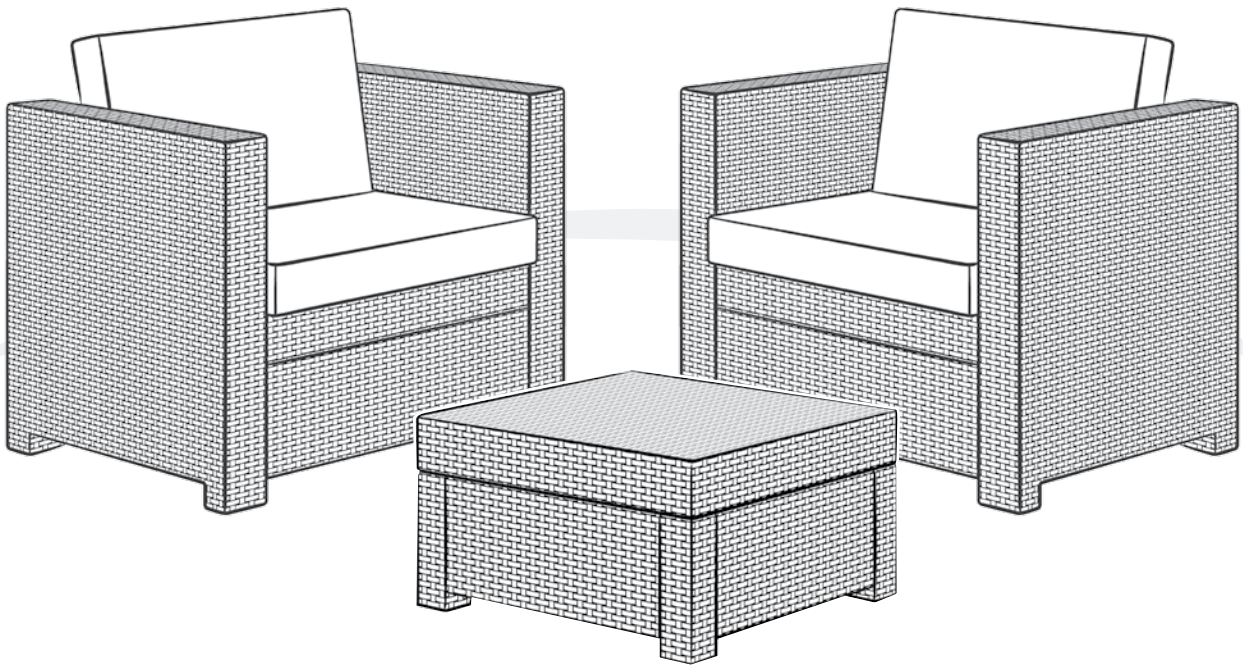

Anmerkungen und Warnhinweise – Bitte sorgfältig vor der Montage lesen

Notes and Warnings – Please Read Carefully Prior to Assembly

Notas e avisos – Leia atentamente antes de proceder à montagem

Anteckningar och varningar – Vänligen läs noggrant innan montering

- Montieren Sie den Sessel bitte auf einer glatten Fläche.
 - Ein zur Montage geeigneter Sechskantschlüssel ist beigelegt.
 - Zusätzlich zu dem Sechskantschlüssel wird noch ein normaler Kreuzschraubendreher benötigt.
 - Es wird empfohlen, alle Schrauben und Muttern per Hand einzudrehen und diese erst nach Beendigung des Zusammenbaus mit dem Sechskantschlüssel festzuziehen.
 - Bewahren Sie den Sechskantschlüssel für einen zukünftigen Gebrauch auf.
 - Zur Reinigung des Sessels sind nur Seifenlauge, Wasser und ein weiches Tuch zu verwenden..
 - Der Sessel ist nur zum Sitzen gedacht und zur angemessenen Benutzung durch eine einzelne Person.
- Please assemble each piece of furniture on a flat surface.
 - A dedicated wrench is enclosed for assembly.
 - Only a standard Phillips screwdriver is required in addition to this wrench.
 - It is recommended to assemble the screws and nuts manually, and only tighten them with the enclosed wrench at the end of the assembly process.
 - It is highly recommended that you retain the wrench for future use.
 - The pieces of furniture should only be cleaned using soap, water, and a soft cloth.
 - The pieces of furniture are only intended for reasonable domestic use.
 - Very hot objects (such as cooking pots) should not be placed directly on the table.
 - Do not sit or stand on the table.
- Monte cada peça de mobília numa superfície plana.
 - É fornecida uma chave adequada para a montagem.
 - Só é necessária uma chave de fendas Phillips para além da fornecida.
 - É recomendável apertar os parafusos e porcas manualmente e aperte apenas com a chave fornecida depois do processo de montagem.
 - É altamente recomendável guardar a chave para futura utilização.
 - As peças de mobília só devem ser limpas com água, sabão e um pano macio.
 - As peças de mobília destinam-se apenas a uma utilização doméstica razoável.
 - Os objectos muito quentes (como panelas) não devem ser colocados directamente sobre a mesa.
 - Não se sente nem permaneça em pé sobre a mesa.
- Montera varje möbel på en plan yta.
 - En särskild nyckel bifogas för montering.
 - Endast en standard Phillips skruvmejsel behövs utöver skiftnyckeln.
 - Manuell montering av skruvar och muttrar rekommenderas och dra åt dem med medföljande skiftnyckel i slutet av monteringsprocessen.
 - Det rekommenderas starkt, att du behåller skiftnyckeln för framtida användning.
 - Möblerna bör endast rengöras med tvål, vatten, och en mjuk duk.
 - Möblerna är enbart avsedda för rimligt hushållsbruk.
 - Mycket heta föremål (såsom matkastruller) bör inte placeras direkt på bordet.
 - Sitt eller stå inte på bordet.



Inhalt • Contents • Conteúdo • Innehåll



LS x1



G x2



RS x1



S x1



B x1



L x1



BC x1

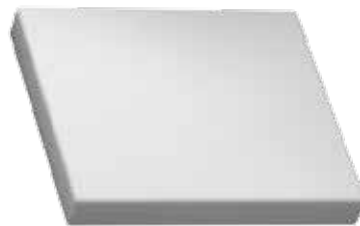

x1



x1



F x1



SP x4



x1



x16



x2



x16



x2



x4



x1

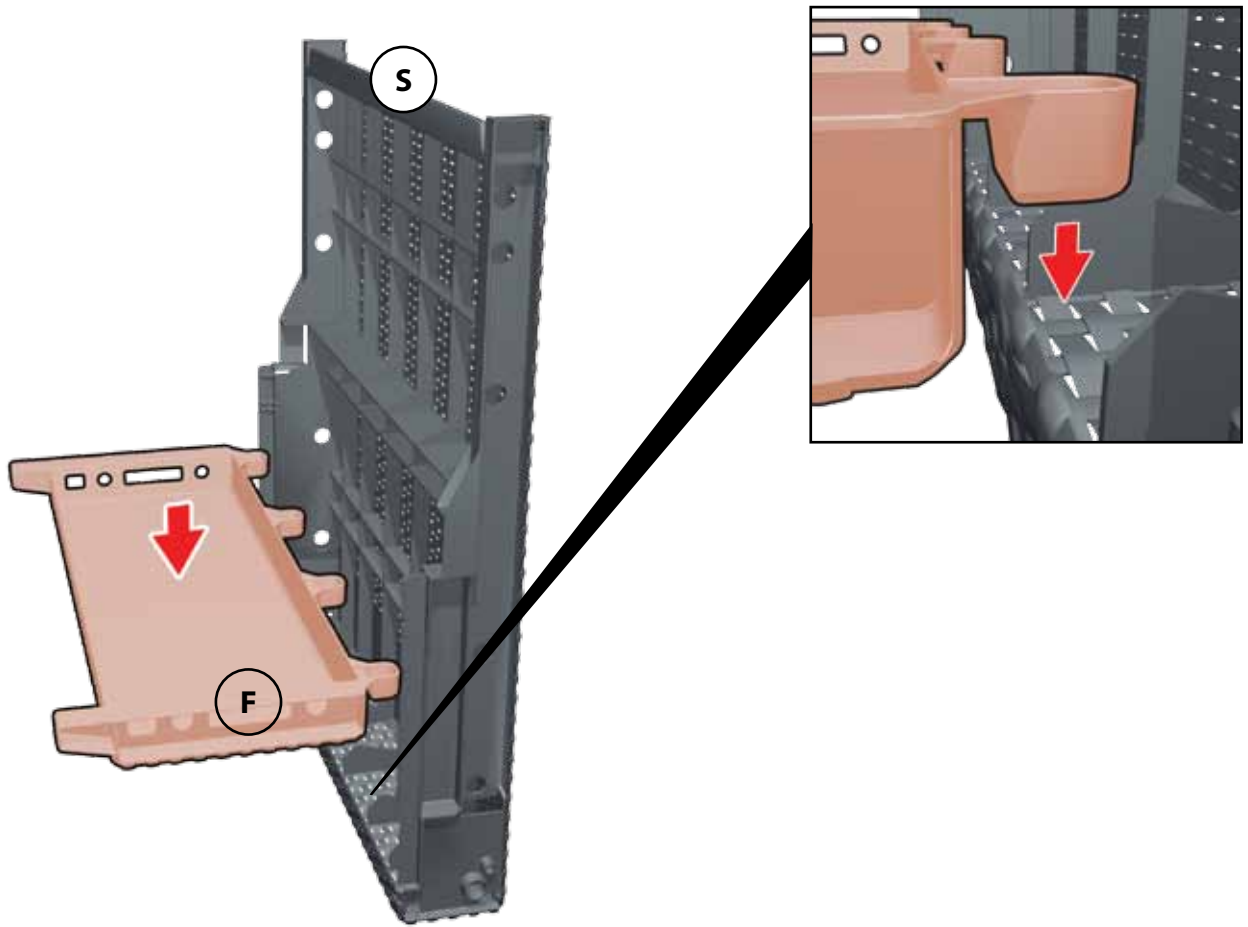

1

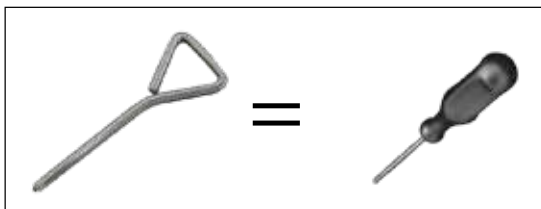

2



1



2

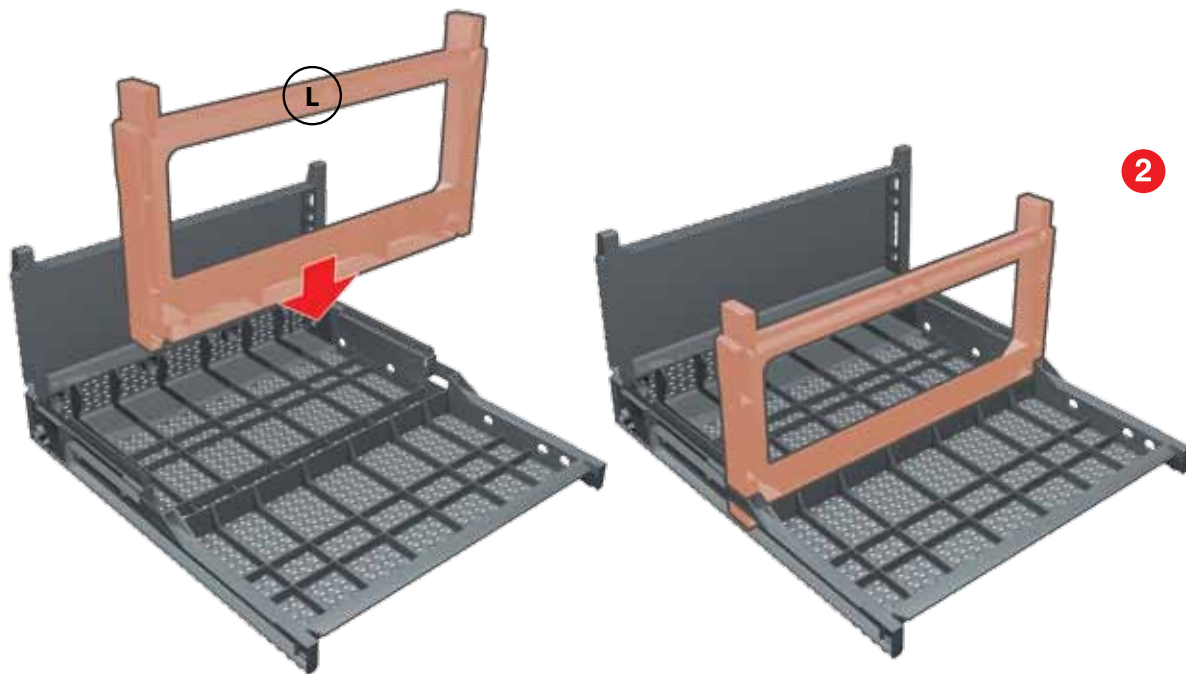

3

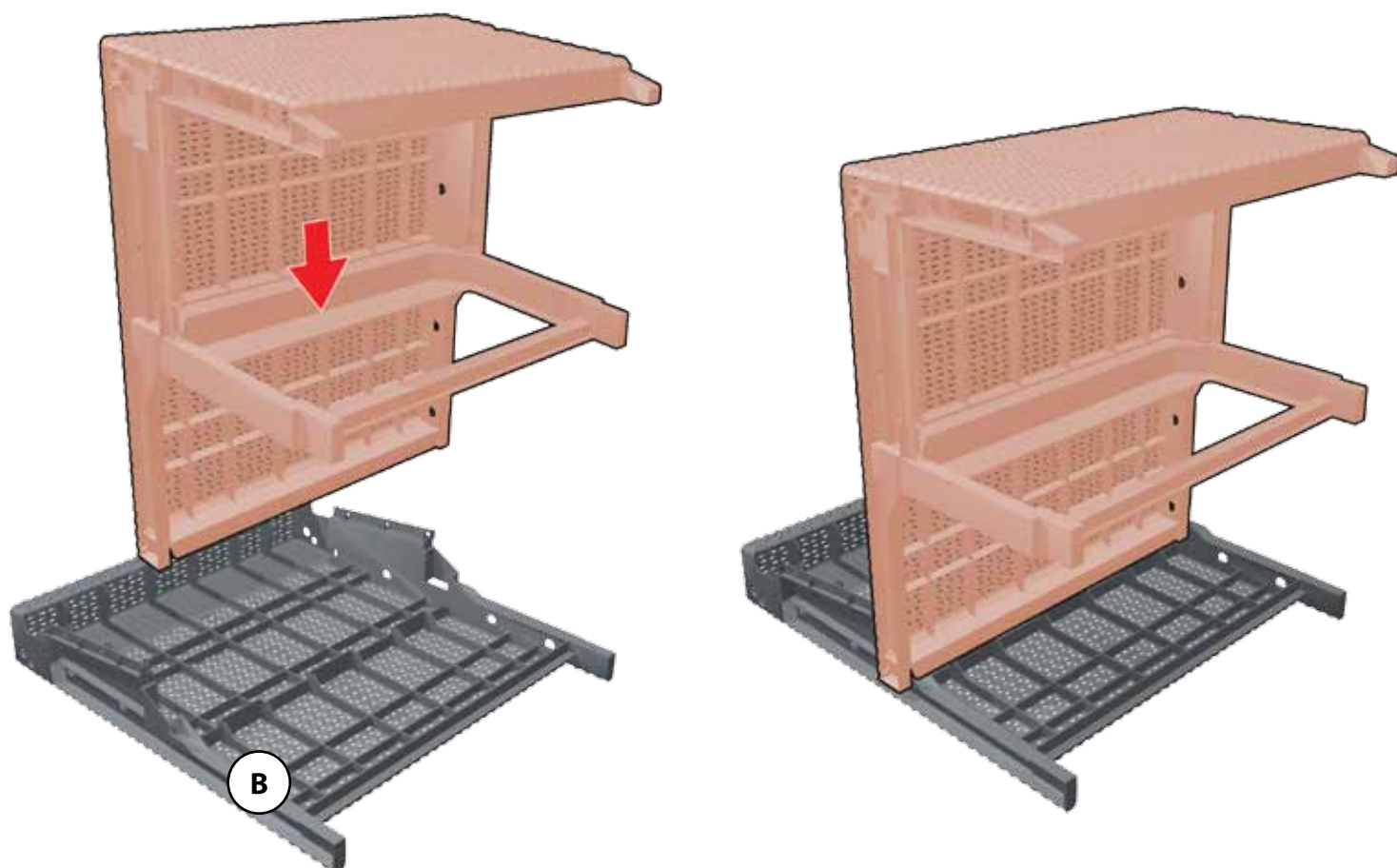

4

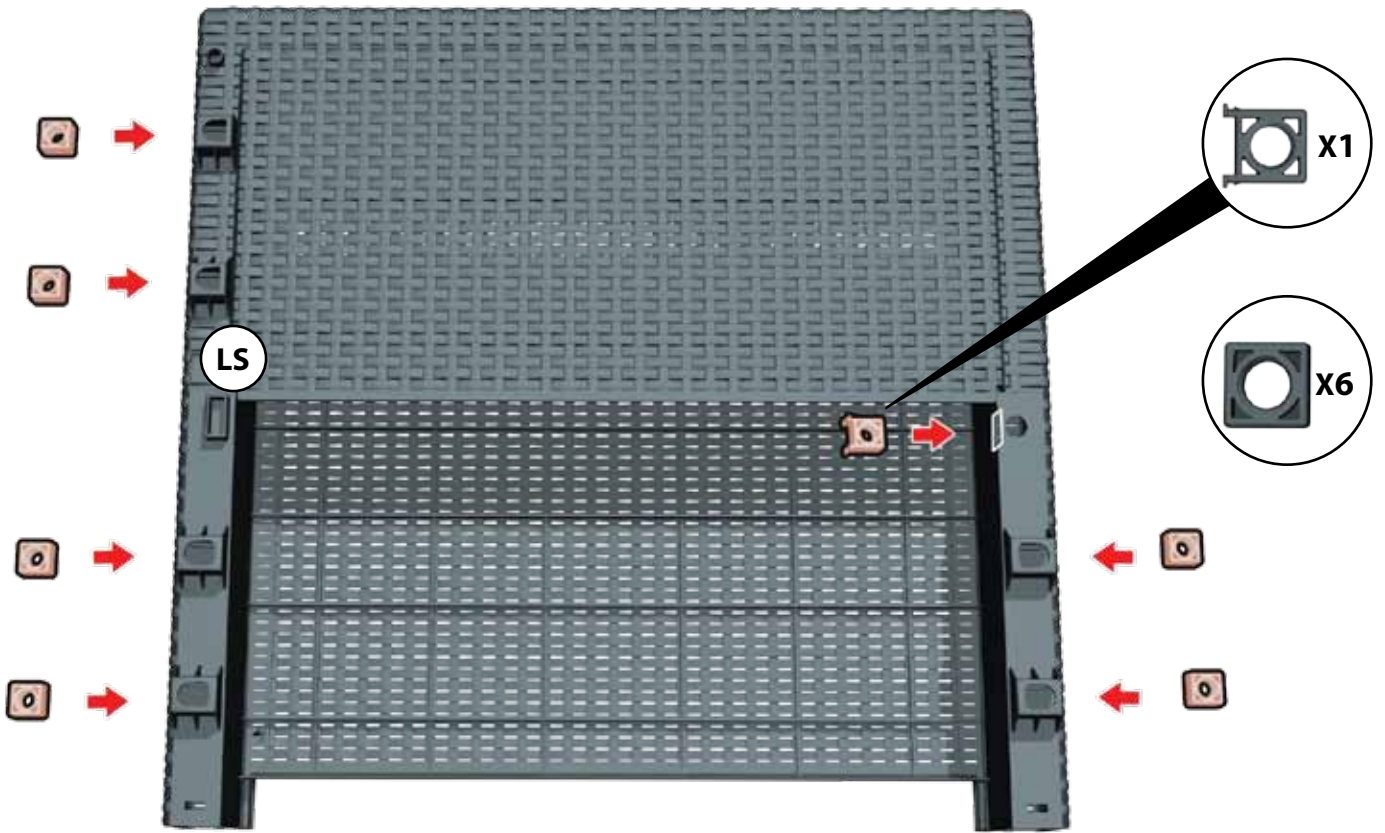

5

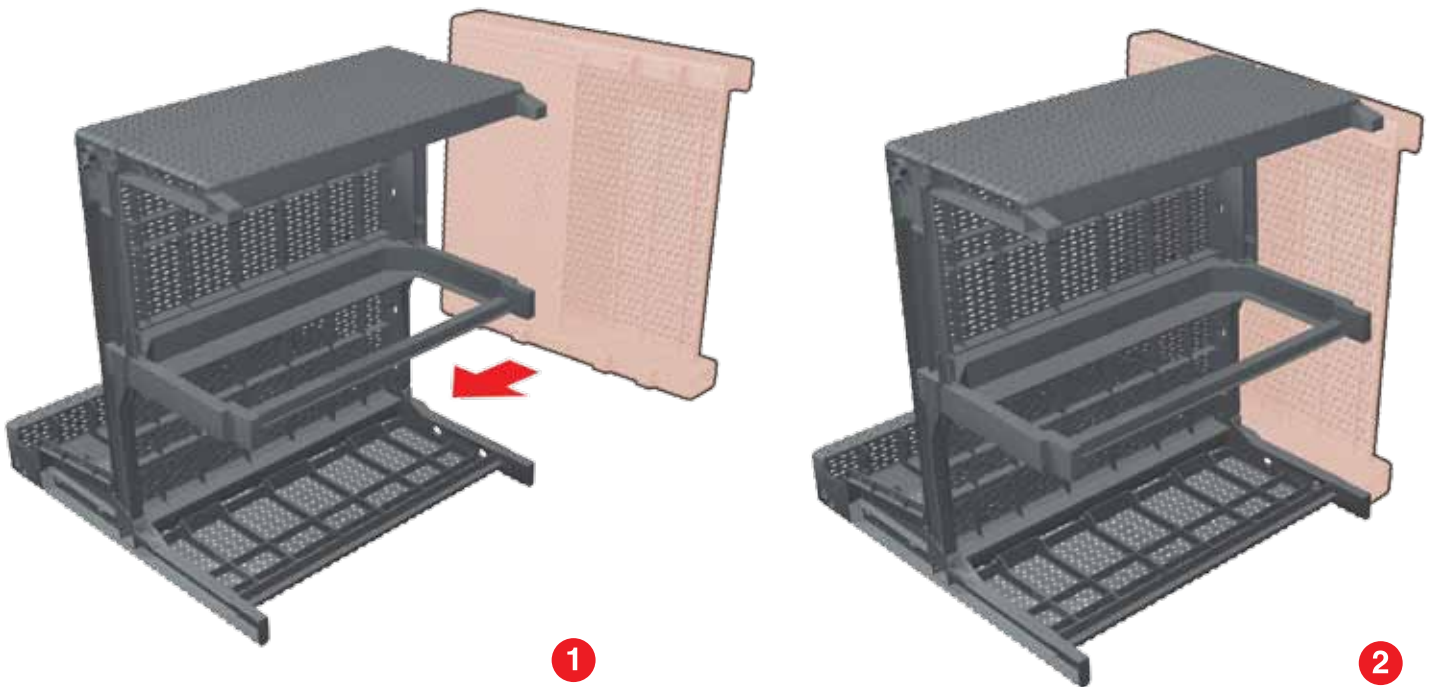

6

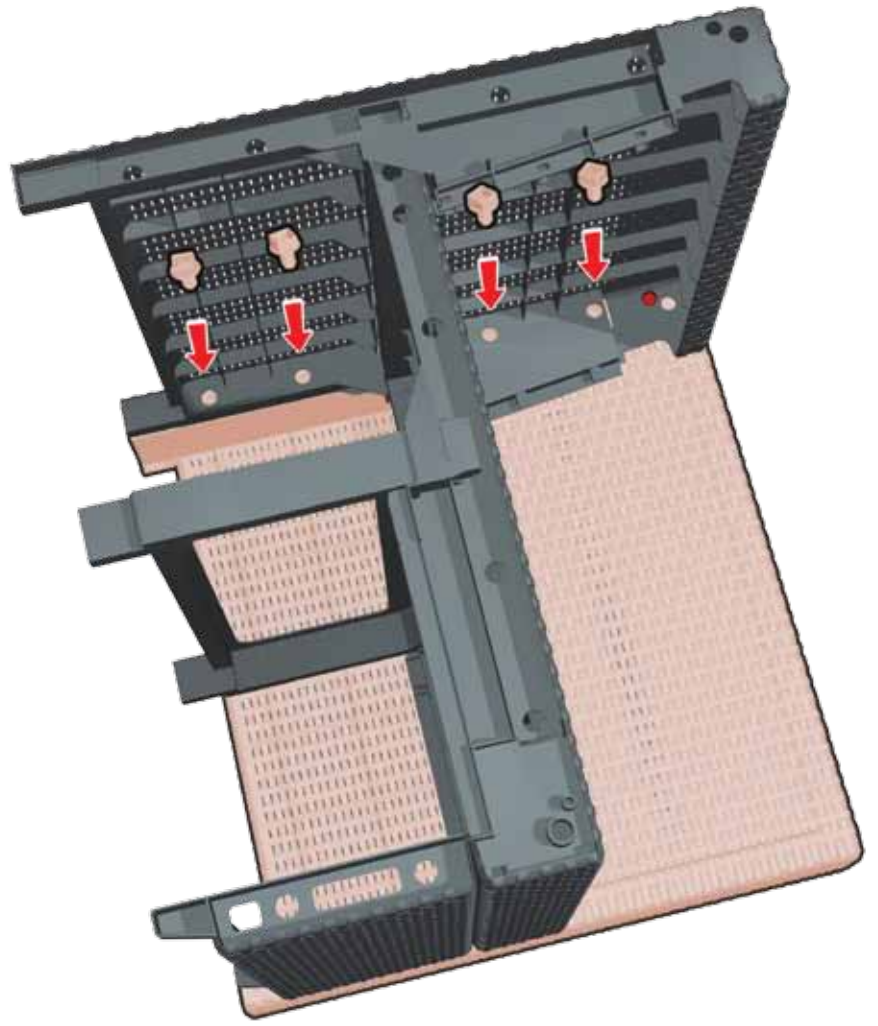
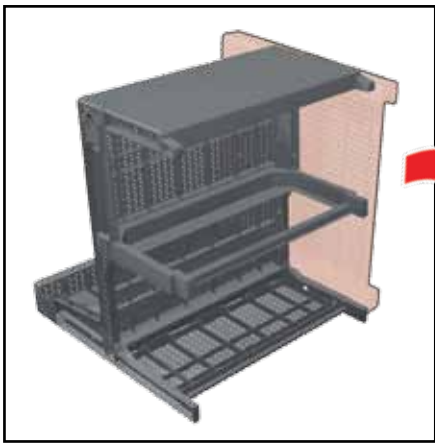

7

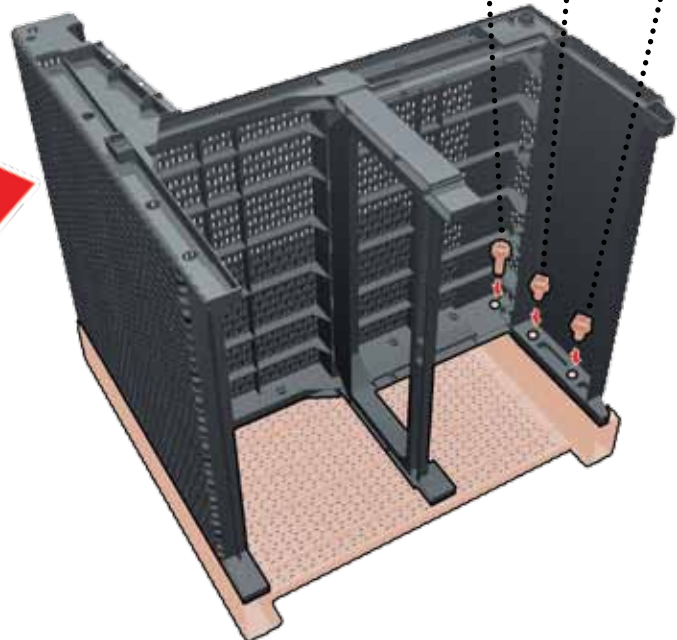
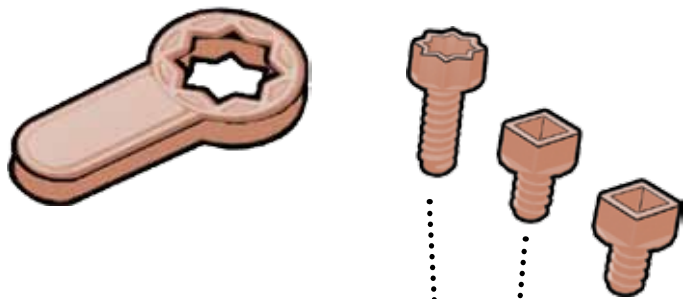
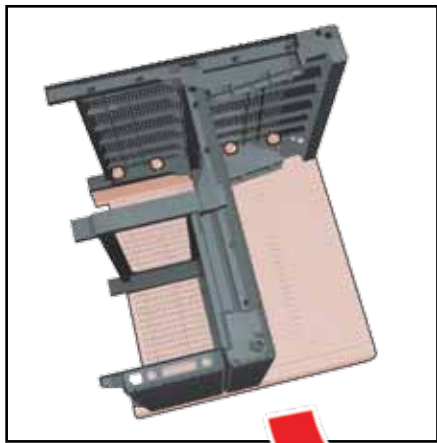

8

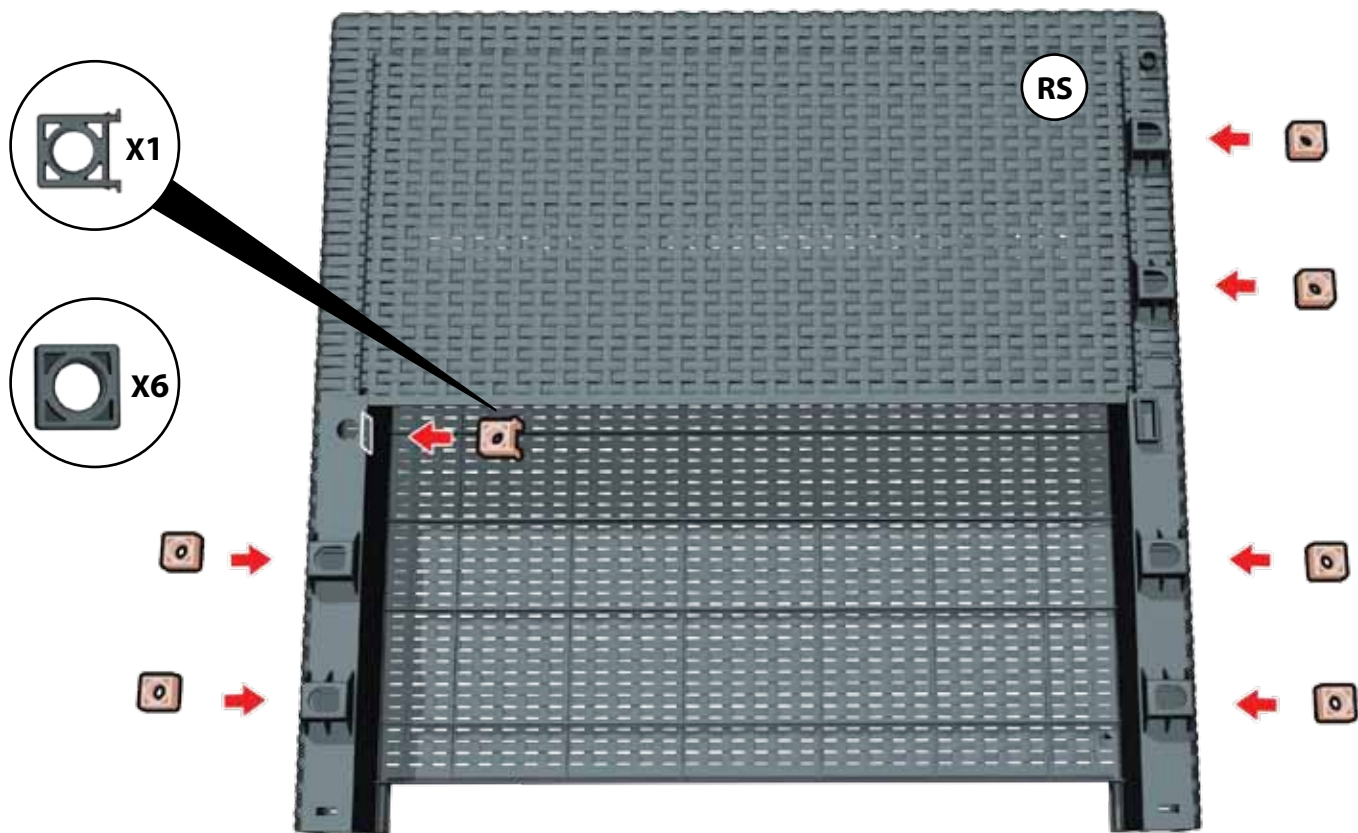

9

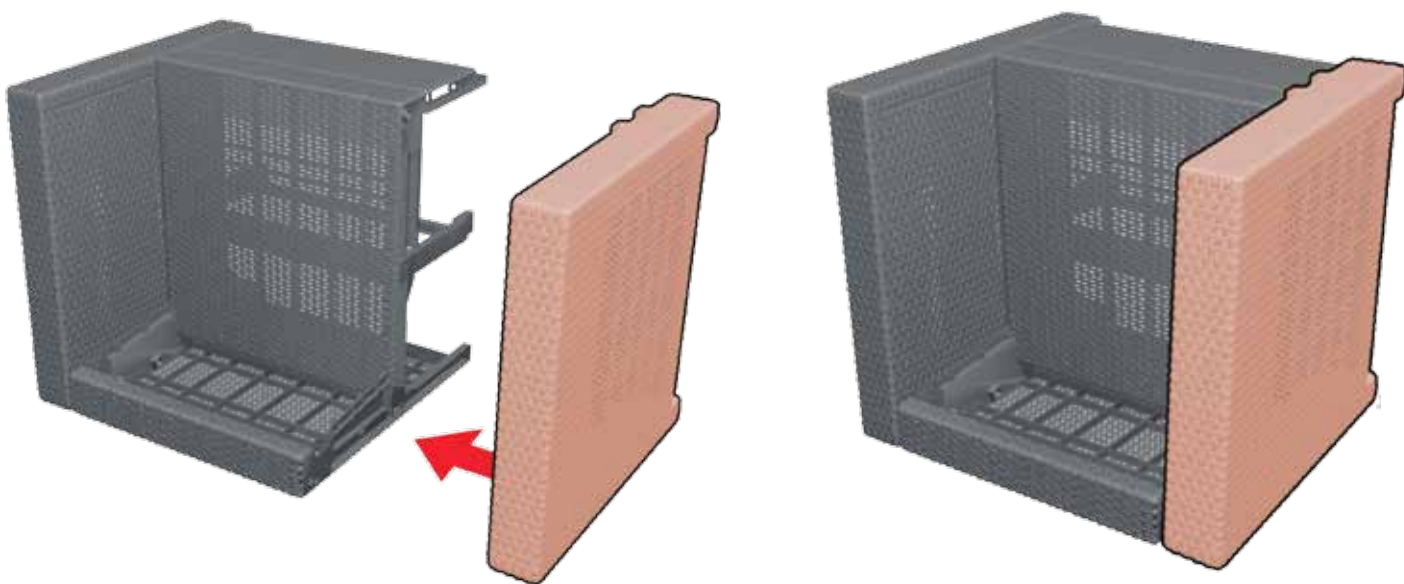

10



11



12

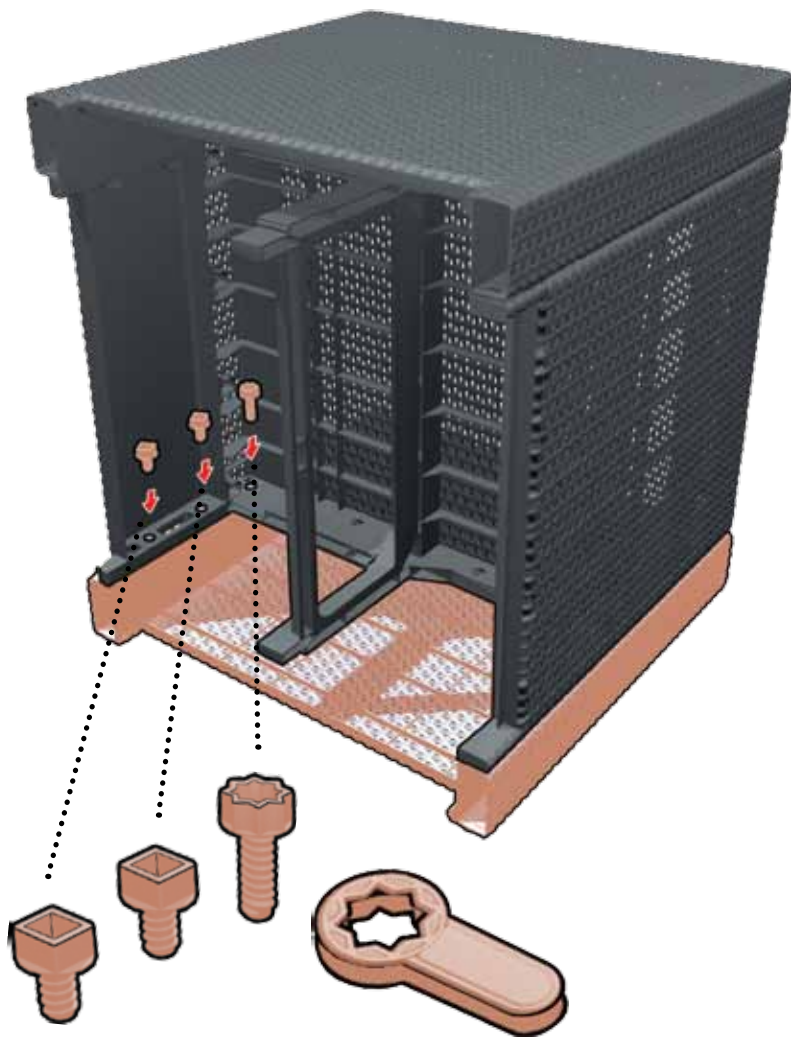

13

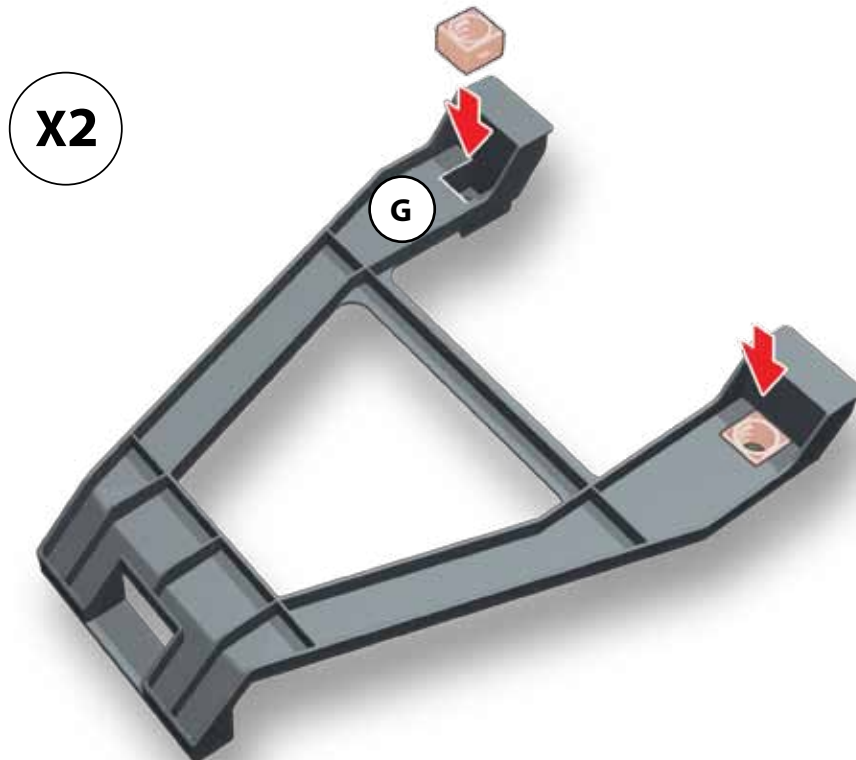

14

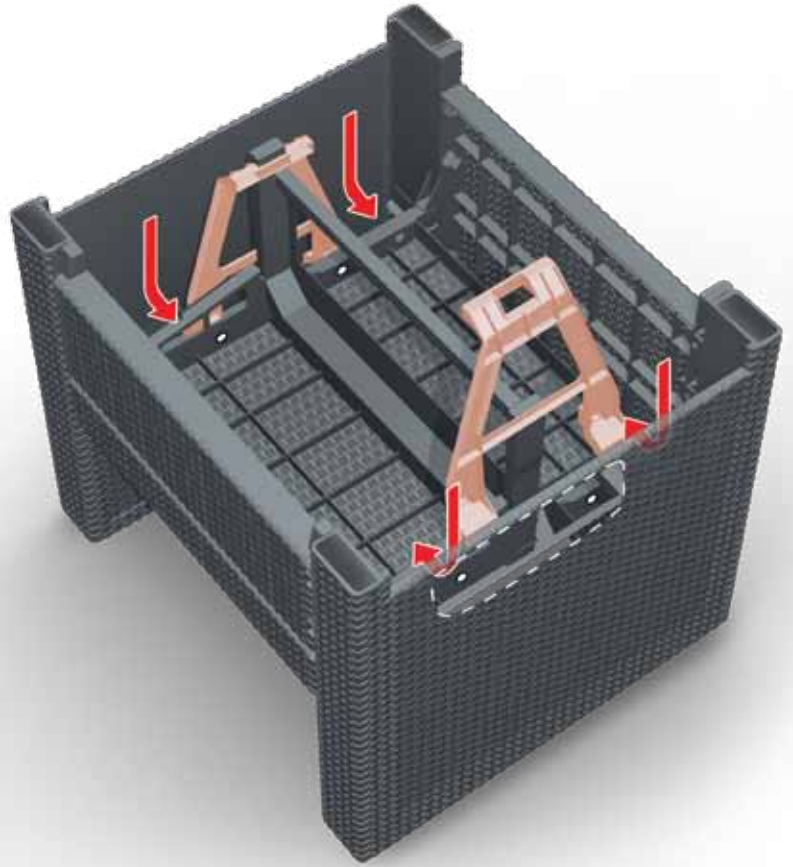

15



16

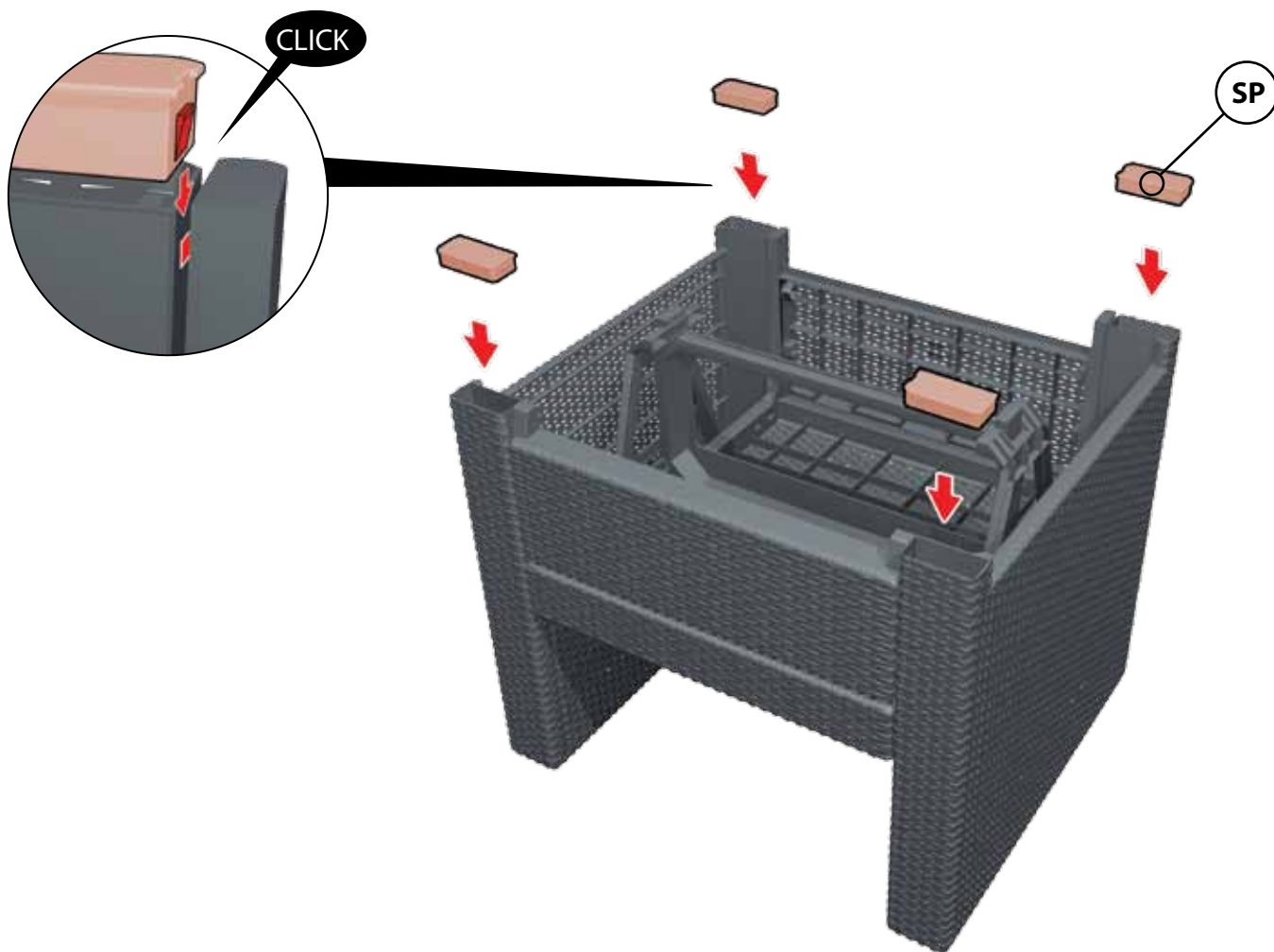

17

**Mit diesem Arbeitsgang ist das Produkt vollständig montiert.
Alle Schrauben können jetzt mit dem Sechskantschlüssel richtig festgezogen werden.**

At this stage, the product is completely assembled.
All of the screws should be given a final tightening with the wrench.

**Nesta fase, o produto está completamente montado.
Neste momento, todos os parafusos devem ser totalmente apertados com a chave indicada.**

I detta skede, är produkten färdigmonterad.
Samtliga skruvar bör få en sista åtdragning med nyckeln i detta skede.



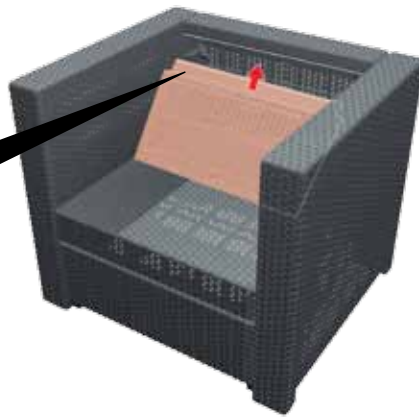
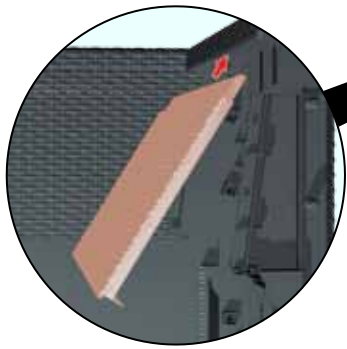
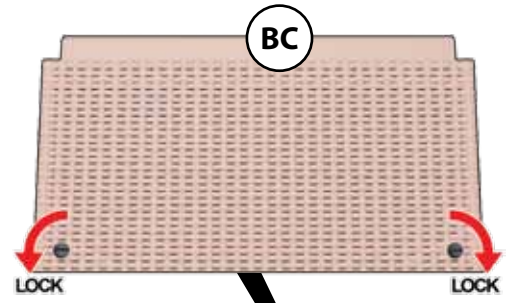
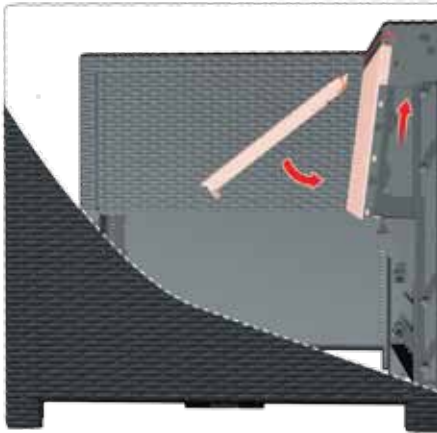

18

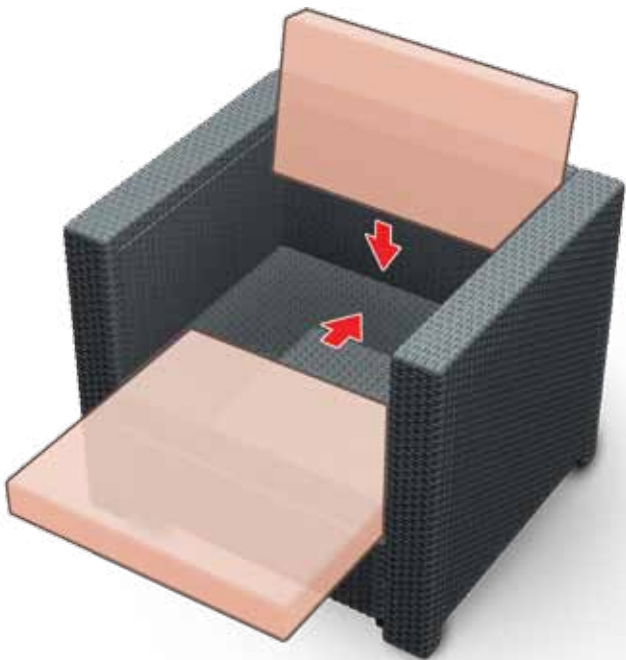

19

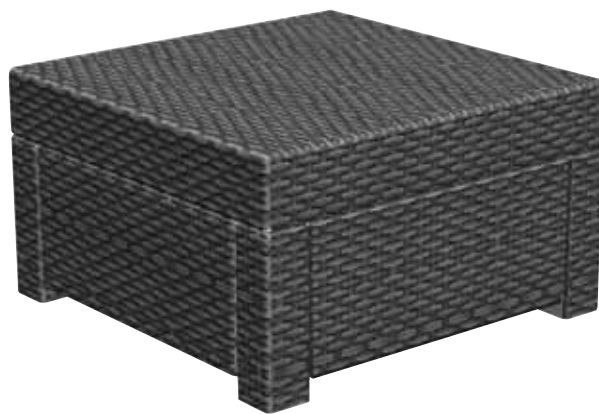

Inhalt • Contents • Conteúdo • Innehåll



TS x4

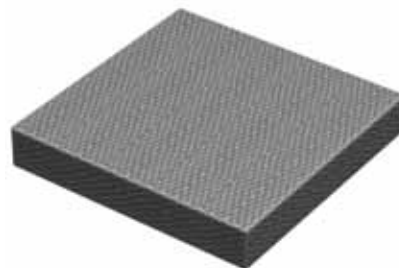

TT x1



P x4

- Ⓔ Option
- Ⓔ Option
- Ⓔ Opção
- Ⓔ Alternativ

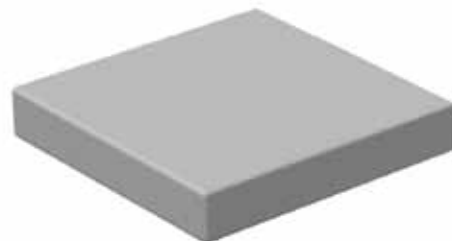

x1

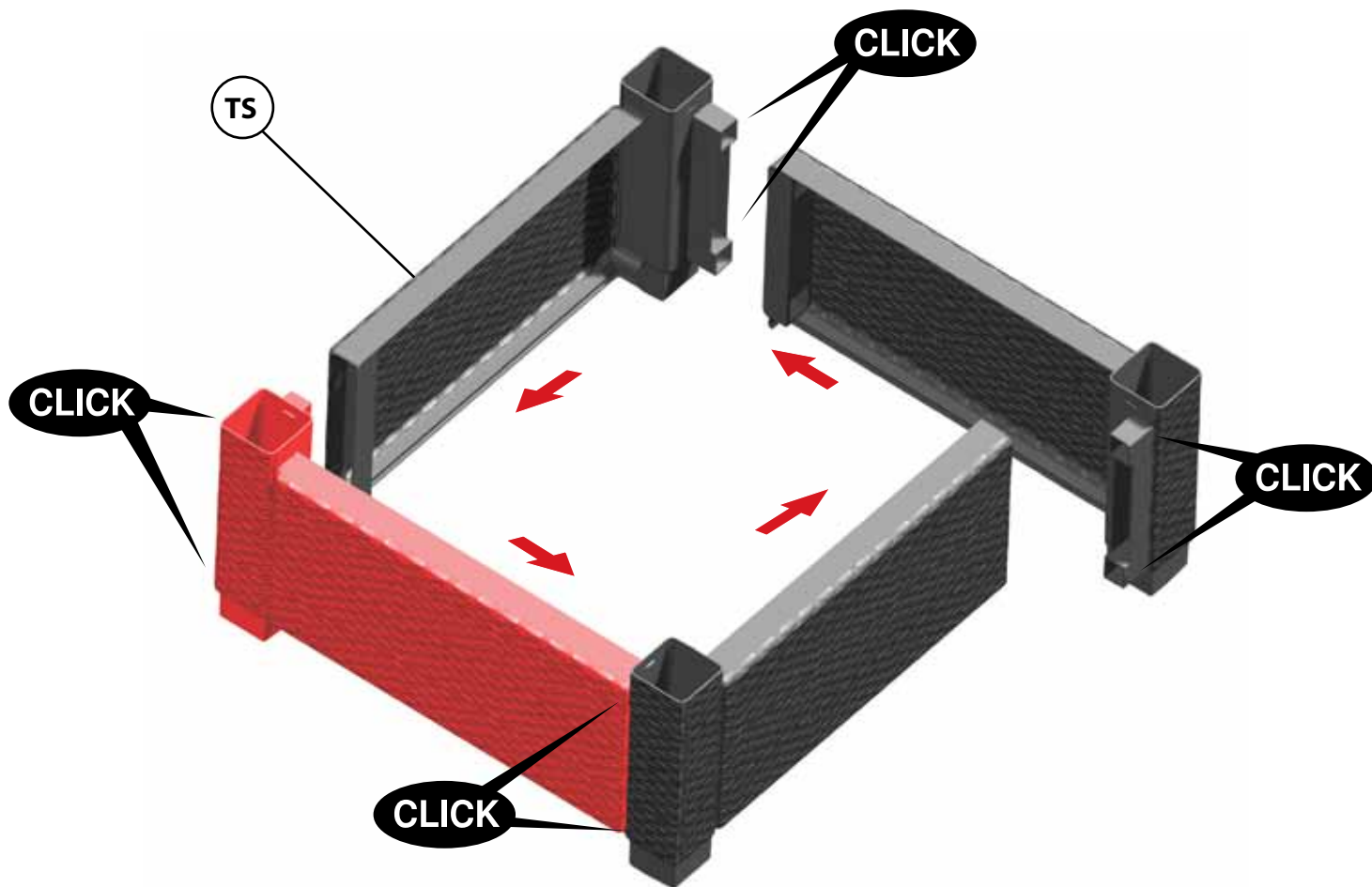

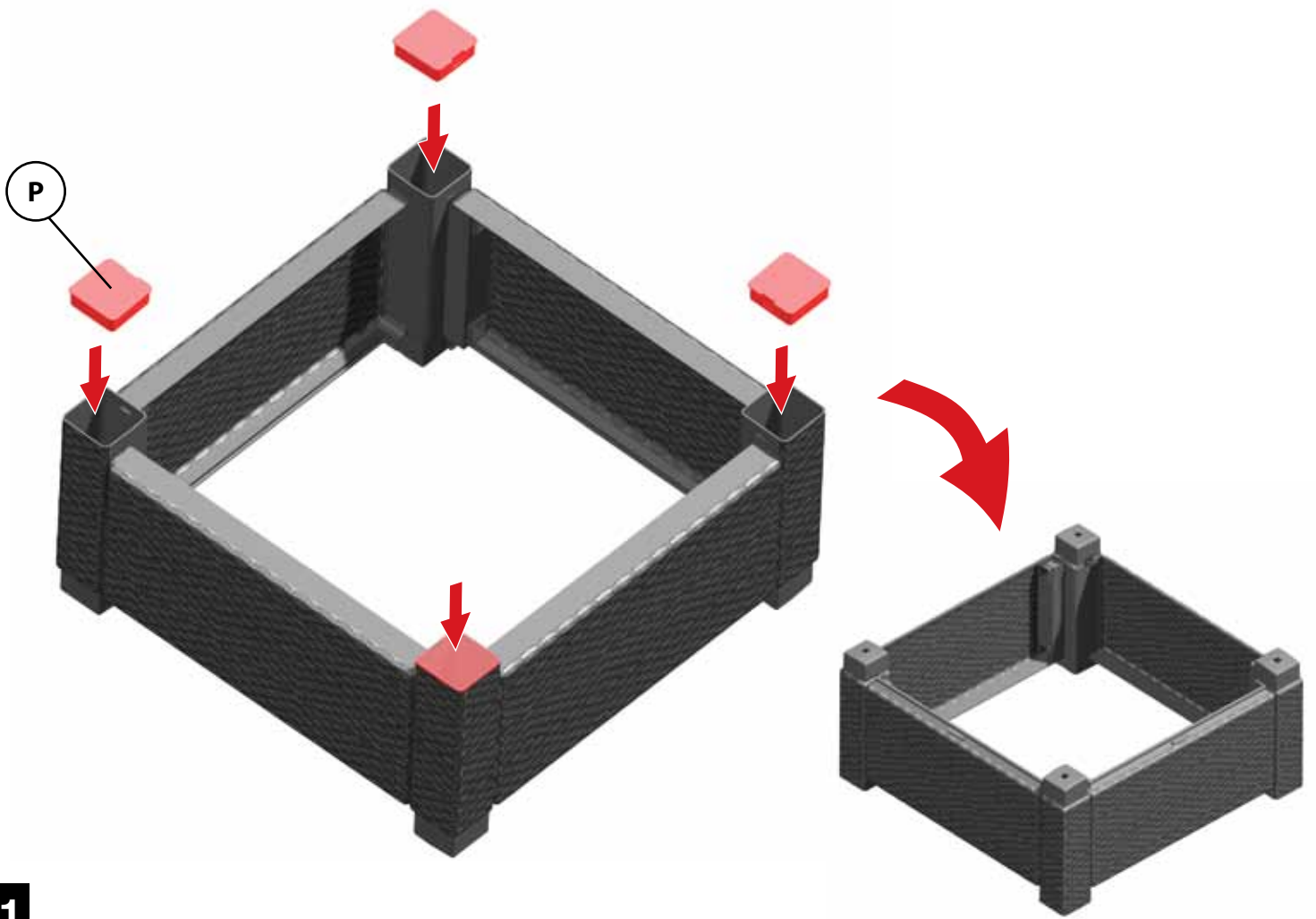

21

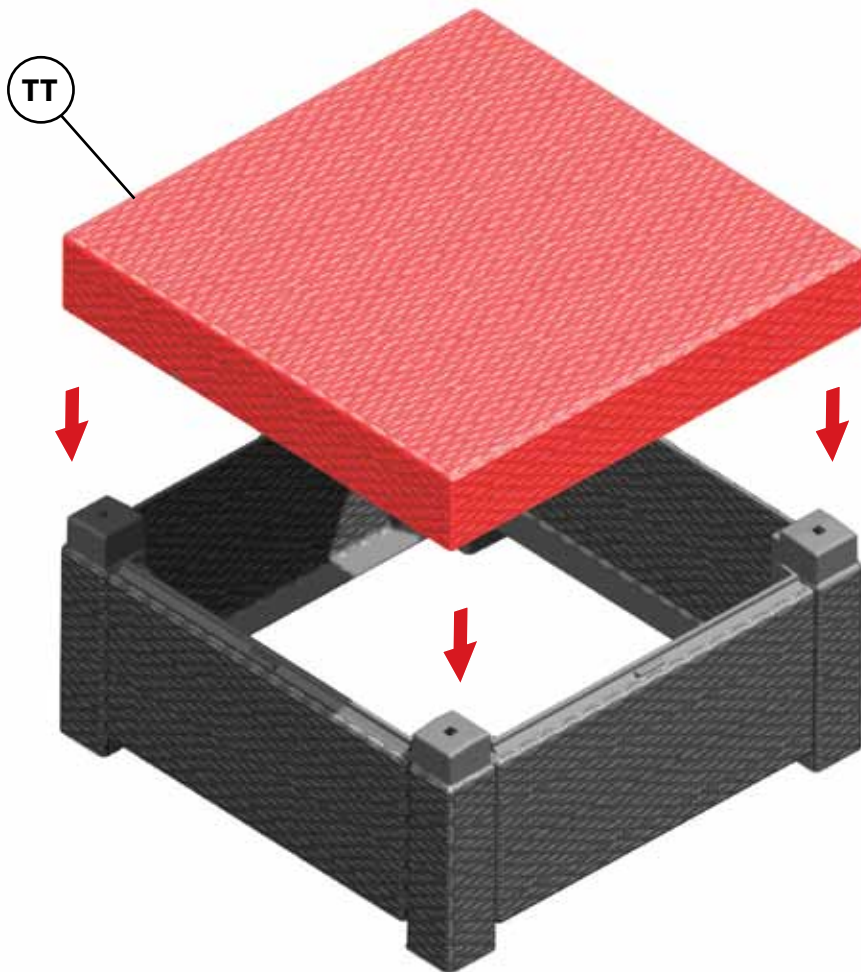

22

